



CombiFlex Pro – for high demands on quality



- For universal use
- Stable square steel stand
- Height adjustable projection surface
- Fold-out mounting bracket for tilting the projection surface, approx. 10° (for keystone correction)
- Tensioning stud mechanism for optimum flatness
- Carry handle for easy transport
- Octagonal steel plate casing
- Casing colour: white aluminium, RAL 9006
- Robust tripod stand

Screen surface

- Front projection, **type D**
- DIN 19045 gain factor, approx. 1.2
- Matt white, foil base

CombiFlex Professional			
External dimensions W/H	Diagonal cm/inch	Weight net kg	Code No.
150/150 cm	212/84	9.5	13005
180/180 cm	255/100	10.7	13006
200/200 cm	283/111	14.5	13007

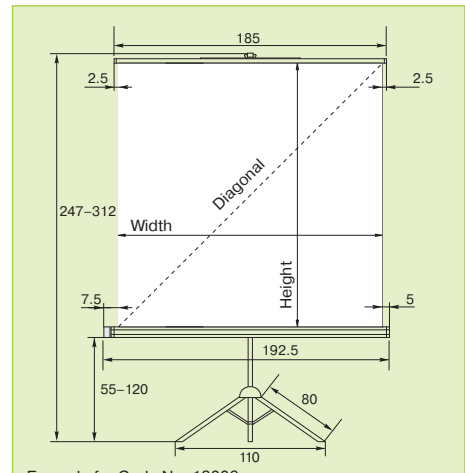

CombiFlex Budget – functional basic model at a feel-good price



- Oval tube steel stand
- Infinitely height adjustable screen
- Carry handle for easy transport
- Octagonal sheet steel casing
- Casing colour: white
- Robust tripod stand

Screen surface

- Front projection, **type D**
- DIN 19045 gain factor, approx. 1.2
- Matt white, woven fabric base

CombiFlex Budget			
External dimensions W/H	Diagonal cm/inch	Weight net kg	Code No.
150/150 cm	212/84	11.0	16410
180/180 cm	255/100	13.0	16411
200/200 cm	283/111	15.0	16412

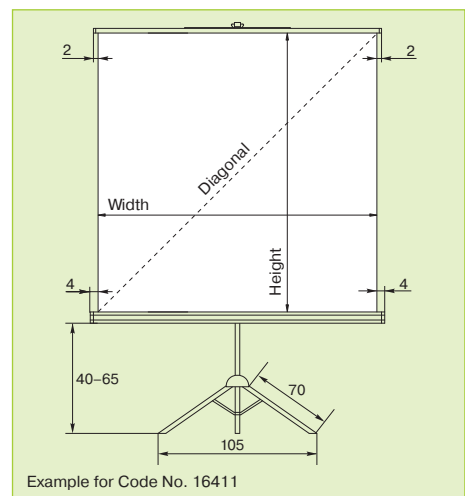

Accessory

Protective cover/transport bag

- For both CombiFlex Pro and CombiFlex Budget
- Made of robust nylon fabric
 - Colour: black

For sizes approx. W/H	Code No.
150/150 cm	13026
180/180 cm	13027
200/200 cm	13030



CombiFlex Mobile – steadier and more mobile than any tripod screen

- Extremely steady thanks to the circular tube steel foot
- **Mobile** on five caster rollers, all lockable
- Screen swivels easily by 360°
- Small stand area (Ø 63 cm)
- **Simple room change** possible with mobile base; optimum for schools and hotels
- Sturdy square steel stand
- Infinitely height adjustable screen
- Fold-out mounting bracket for tilting the screen by approx. 10° (for keystone correction)
- Octagonal sheet steel housing
- Casing colour: silver-grey, RAL 9006

Projection surface

- Front projection, **type D**
- DIN 19045 gain factor, approx. 1.2
- Matt white, foil base



Handle



Height adjustment

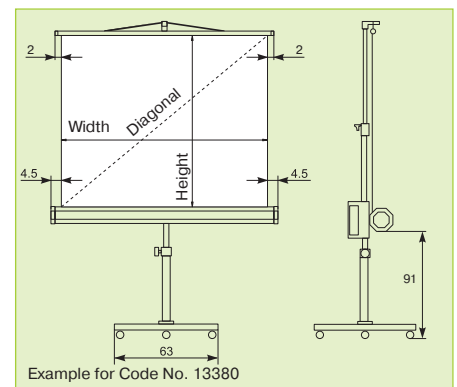

CombiFlex Mobile			
External dimensions W/H	Diagonal cm/inch	Weight net kg	Code No.
150/150 cm	212/84	10.8	13380
180/180 cm	255/100	14.4	13381
200/200 cm	283/111	16.2	13382